



## GUIDELINES FOR POSTERS

1. The maximum dimensions of posters are **1.016 m (40 in.) high by 1.46 m (57 in.) wide**. The posters have to fit on the provided display boards (see attached sketch next page) which have a surface made of soft material to accept male Velcro tape. A supply of Velcro tape will be available for your use during set-up.
2. Written text should be legible from 2 m (6 ft.) distance. The title of the poster should be at the top of the board with a character size of at least 5 cm (2 in.) high.
3. Posters should cover the key points of your presentation. Remember that posters are visual presentations of information. Rely on graphs, charts, tables and pictures to communicate information rather than text. **The ideal poster should draw attention, inform, and stimulate discussion.**
4. The Summit official language is English and therefore posters must be in English.
5. **Posters cannot be sent in advance.** They must be brought by their presenters, who are responsible for setting up and removing their material. **Any material left will be discarded at the end of the Summit.**
6. Poster numbers will be assigned during set-up.
7. Posters will be displayed from **August 22 to 25 in the Exhibition Hall**. Please note that participants will be invited to visit the posters particularly during the breaks (see the Program on the web site for the hours). While you are not expected to remain near your poster during the entire opening hours - we do encourage you to be there during coffee and lunch breaks where the Exhibition Hall is anticipated to be at its busiest.

Set-up	Exhibition Hall Opening Hours	Dismantling
Monday, August 22nd 8:00 a.m. to 2:00 p.m.	Monday, August 22nd 5:30 p.m. to 7:30 p.m. Tuesday, August 23 <sup>rd</sup> to Thursday, August 25th 9:30 a.m. to 5:00 p.m.	Thursday, August 25th 5:00 p.m. to 8:00 p.m.

# POSTERBOARD

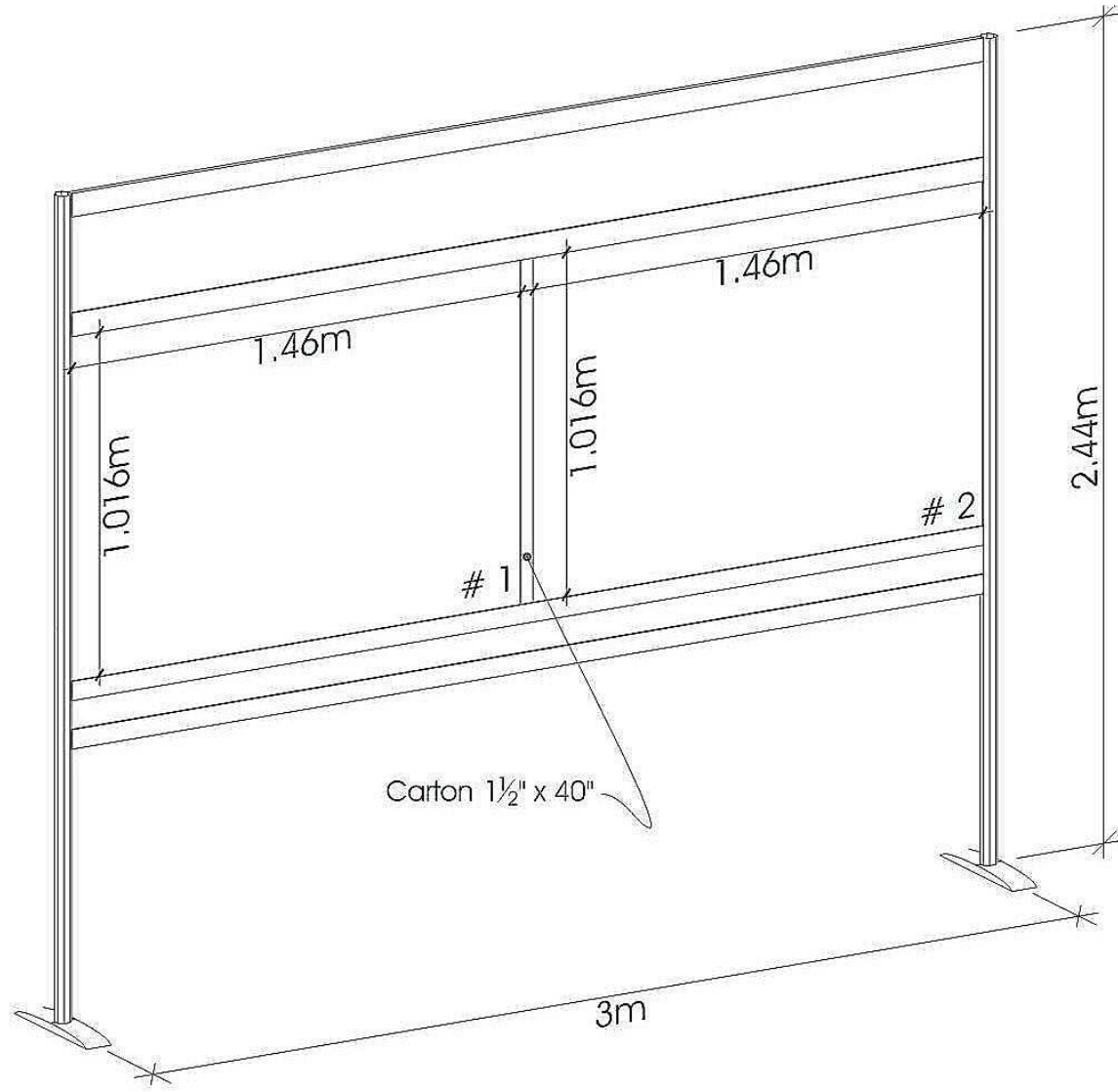

## Information:

**Ecocity 2011 Presenters Services**  
417, St-Pierre, Suite 203  
Montréal (Quebec) Canada H2Y 2M4

Telephone: (514) 395-1808 x21  
Fax: (514) 395-1801  
E-mail: [program@ecocity2011.com](mailto:program@ecocity2011.com)